

## An Application on Harmonic Mean Labeling of Variations in Triangular Snake Graphs

T. Christy<sup>1</sup>, G. Palani<sup>2,\*</sup>, E. Chandrasekaran<sup>3</sup>

<sup>1</sup>Assistant Professor, Department of Mathematics, Patrician College of Arts and Science, Affiliated to University of Madras, Tamil Nadu, India.

<sup>2</sup>Assistant Professor, Department of Mathematics, Dr. Ambedkar Government Arts College, Tamil Nadu, India.

<sup>3</sup>Professor of Mathematics, Veltech Rangarajan Dr Sagunthala R&D Institute of Science and Technology, Tamil Nadu, India.

\*Corresponding author: E-mail: gpalani32@yahoo.co.in

### Article History:

Received: 15-01-2024

Revised: 26-03-2024

Accepted: 18-04-2024

---

### Abstract:

A graph  $G$  with  $p$  vertices and  $q$  edges is called a harmonic mean(HM) labeling if it is possible to label the vertices  $x \in v$  with distinct labels  $\rho(x)$  from  $\{1, 2, \dots, q + 1\}$  in such a way that each edge  $e = ab$  is labeled with  $\rho(ab) = \left\lfloor \frac{2\rho(a)\rho(b)}{\rho(a)+\rho(b)} \right\rfloor$  or  $\left\lceil \frac{2\rho(a)\rho(b)}{\rho(a)+\rho(b)} \right\rceil$  then the edge labels are distinct.

In this case  $\rho$  is called Harmonic mean(HM) labeling of  $G$ . In this paper we introduce new graphs obtained from triangular snake graph  $TS_n$  such as  $TS_n \circ K_1$ , and prove that they are Harmonic Mean labeling graphs.

**Keywords:** HM labeling,  $TS_n \circ K_1$  graphs.

---

## 1. Introduction

Let  $G = (V, E)$  be a  $(p, q)$  graph with  $p = |V(G)|$  vertices and  $q = |E(G)|$  edges, where  $V(G)$  and  $E(G)$  respectively denote the vertex set and edge set of the graph  $G$ . In this paper, we consider the graphs which are simple, finite and undirected for graph theoretic terminology and notations we refer to Haray [2]. The Concept of graph labeling was introduced by Rosa in 1967. A detailed survey of graph labeling is available in Gallian [1]. The concept of Mean labeling of graph was introduced by S. Somasundaram, R. Ponraj and S.S. Sandhya [3]. Some of the harmonic mean graphs are investigated by S. Meena and M. Sivasakthi in [4]. The concept of Harmonic Mean labeling of graph was introduced by S. Somasundaram, R. Ponraj and S.S. Sandhya [5,6] and they investigated the existence of Harmonic mean labeling of several family of graphs such as this concept was then studied by several authors and studied their behavior in [7], [8], [9], and [10].

## 2. Preliminaries

### Definition 2.1. Mean Labeling

A function  $\rho$  is called mean labeling for a graph  $G = (V, E)$  if  $\rho: V \rightarrow \{0, 1, 2, 3, \dots, q\}$  is injective and the induce function  $\rho^*: E \rightarrow \{1, 2, 3, \dots, q\}$  defined as  $\rho^* = \left\lfloor \frac{\rho(a)+\rho(b)}{2} \right\rfloor$  or  $\left\lceil \frac{\rho(a)+\rho(b)}{2} \right\rceil$  is bijective for every edge. A graph  $G$  is called mean labeling.

**Definition 2.2.** *Harmonic Mean (HM) Labeling*

A graph  $G = (V, E)$  with  $p$  vertices and  $q$  edges is called a harmonic mean (HM) graph if it is possible to label the vertices  $x \in v$  with distinct labels  $\rho(x)$  from  $\{1, 2, \dots, q + 1\}$  in such a way that when each edge  $e = ab$  is labeled with  $\rho(ab) = \left\lfloor \frac{2\rho(a)\rho(b)}{\rho(a)+\rho(b)} \right\rfloor$  or  $\left\lceil \frac{2\rho(a)\rho(b)}{\rho(a)+\rho(b)} \right\rceil$  then the edge labels are distinct.

**Definition 2.3.**  *$TS_n \circ K_1$  Graph*

The Triangular snake is obtained from the path  $P_n$  by replacing each edge of the path by a cycle  $C_3$ . Each vertex of triangular snake graph  $T_n$  is attached with an edge and the graph obtained is called as  $TS_n \circ K_1$

**3. Main Results**

**Theorem 3.1.** For every  $n \geq 1$ , there exists a Triangular snake graph  $TS_n \circ K_1$ , which admits HM labeling.

**Proof.** Consider the  $TS_n \circ K_1$  graph with Vertex set  $V = \{a_i, b_i, c_i, d_i; 1 \leq i \leq n\}$  and Edge set  $E = \{(a_i b_i) \cup (c_i b_i) \cup (c_i c_{i+1}) \cup (c_i d_i); 1 \leq i \leq n\}$

Now let us define a function

$$\rho: v \rightarrow \{1, 2, 3, \dots, q + 1\}$$

Let us label the vertices as follows.

$$\rho(a_1) = 6; \rho(a_{i+1}) = 5i + 3; 1 \leq i \leq n - 1$$

$$\rho(b_i) = 5i - 1; \rho(c_i) = 5i - 3; 1 \leq i \leq n$$

$$\rho(d_1) = 1; \rho(d_{i+1}) = 5i; 1 \leq i \leq n - 1$$

The induced edge labeling is as follows

$$\rho^*(a_1 b_1) = 4; \rho^*(a_{i+1} b_{i+1}) = 5i + 3; 1 \leq i \leq n - 1$$

$$\rho^*(b_i c_i) = 5i - 3; \rho^*(c_{i+1} b_i) = 5i; 1 \leq i \leq n$$

$$\rho^*(c_1 c_2) = 3; \rho^*(c_{i+1} c_{i+2}) = 5i + 4; 1 \leq i \leq n$$

$$\rho^*(d_i c_i) = 5i - 4; 1 \leq i \leq n$$

Thus,  $TS_n \circ K_1$  is a HM labeling.

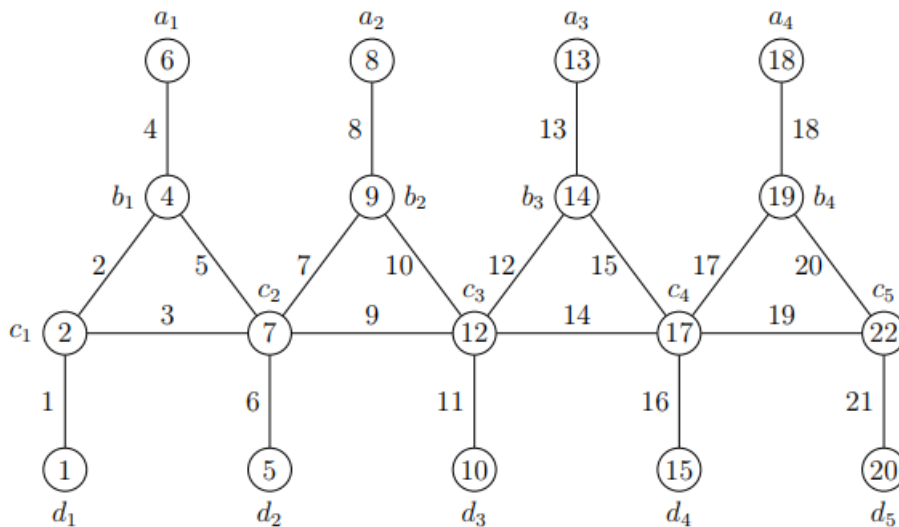

Fig 1.  $TS_4 \circ K_1$

**Theorem 3.2.** For every  $n \geq 1$ , there exists a Alternate Triangular snake graph  $A(TS)_n \circ K_1$ , which admits HM labeling.

**Proof.** Consider the  $A(TS)_n \circ K_1$  graph with Vertex set  $V = \{a_i, b_i, c_i, d_i; 1 \leq i \leq n\}$  and Edge set  $E = \{(a_i b_i) \cup (c_i b_i) \cup (c_i c_{i+1}) \cup (c_i d_i); 1 \leq i \leq n\}$

Now let us define a function

$$\rho: v \rightarrow \{1, 2, 3, \dots, q + 1\}$$

Let us label the vertices as follows

$$\rho(a_i) = 7i - 6; \rho(b_i) = 7i - 5; 1 \leq i \leq n.$$

$$\rho(c_1) = 4; \rho(c_{2i}) = 7i - 2; i \equiv 0(\text{mod}2) \rho(c_{2i+1}) = 7i + 3; i \equiv 1(\text{mod}2)$$

$$\rho(d_{2i}) = 7i; i \equiv 0(\text{mod}2) \rho(d_{2i-1}) = 7i - 1; i \equiv 1(\text{mod}2)$$

The induced edge labeling is as follows

$$\rho^*(a_i b_i) = 7i - 6; 1 \leq i \leq n$$

$$\rho^*(b_{2i-1} c_{2i-1}) = 7i - 5; i \equiv 1(\text{mod}2) \rho^*(b_{2i} c_{2i}) = 7i - 4; i \equiv 0(\text{mod}2)$$

$$\rho^*(c_{2i-1} c_{2i}) = 7i - 3; \rho^*(c_{2i+1} c_{2i}) = 7i; 1 \leq i \leq n$$

$$\rho^*(d_{2i-1} c_{2i-1}) = 7i - 2; i \equiv 1(\text{mod}2) \rho^*(d_{2i} c_{2i}) = 7i - 1; i \equiv 0(\text{mod}2)$$

Thus,  $A(TS)_n \circ K_1$  is a HM labeling.

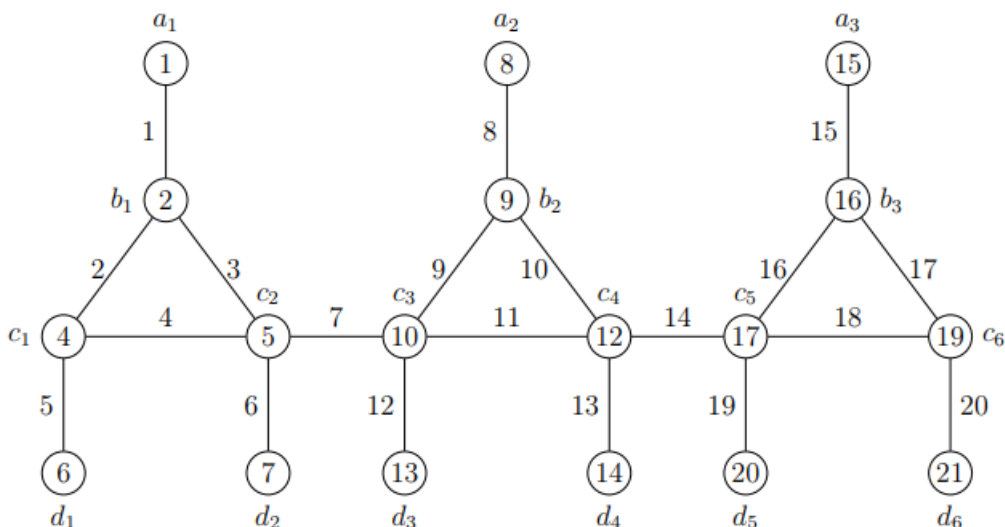

Fig. 2.  $A(TS)_3 \circ K_1$

**Theorem 3.3.** For every  $n \geq 1$ , there exists a Double Triangular snake graph  $DTS_n \circ K_1$ , which admits HM labeling.

**Proof.** Consider the  $DTS_n \circ K_1$  graph with Vertex set  $V = \{a_i, b_i, c_i, d_i, a'_i, b'_i; 1 \leq i \leq n\}$  and Edge set  $E = \{(a_i b_i) \cup (d_i b_i) \cup (c_i d_i) \cup (d_i d_{i+1}) \cup (b'_i d'_i), \cup (a'_i b'_i); 1 \leq i \leq n\}$ .

Now let us define a function

$$\rho: v \rightarrow \{1, 2, 3, \dots, q + 1\}$$

Let us label the vertices as follows.

$$\begin{aligned} \rho(a_1) &= 1; & \rho(a_{i+1}) &= 8i + 3; & 1 \leq i \leq n - 1 \\ \rho(b_1) &= 2; & \rho(b_{i+1}) &= 8i + 4; & 1 \leq i \leq n - 1 \\ \rho(c_1) &= 4; & \rho(c_{i+1}) &= 8i - 2; & 1 \leq i \leq n - 1 \\ \\ \rho(d_1) &= 5; & \rho(d_{i+1}) &= 8i + 2; & 1 \leq i \leq n - 1 \\ \\ \rho(b'_i) &= 8i - 1; & \rho(a'_i) &= 8i + 1; & 1 \leq i \leq n \end{aligned}$$

The induced edge labeling is as follows

$$\begin{aligned} \rho^*(a_1 b_1) &= 1; & \rho^*(a_{i+1} b_{i+1}) &= 8i + 3; & 1 \leq i \leq n - 1 \\ \rho^*(d_1 c_1) &= 4; & \rho^*(d_{i+1} c_{i+1}) &= 8i - 1; & 1 \leq i \leq n - 1 \\ \\ \rho^*(a'_i b'_i) &= 8i; & \rho^*(d_i b_i) &= 8i - 6; & 1 \leq i \leq n \\ \rho^*(d_2 b_1) &= 3; & \rho^*(d_{i+1} b_i) &= 8i + 6; & 2 \leq i \leq n \end{aligned}$$

$$\rho^*(b'_1 d_1) = 5; \rho^*(b'_{i+1} d_{i+1}) = 8i + 4; \rho^*(b'_i d_{i+1}) = 8i + 1; 1 \leq i \leq n$$

$$\rho^*(d_1 d_2) = 6; \rho^*(d_{i+1} d_{i+2}) = 8i + 5; 1 \leq i \leq n - 1$$

Thus,  $DTS_n \circ K_1$  is a HM labeling.

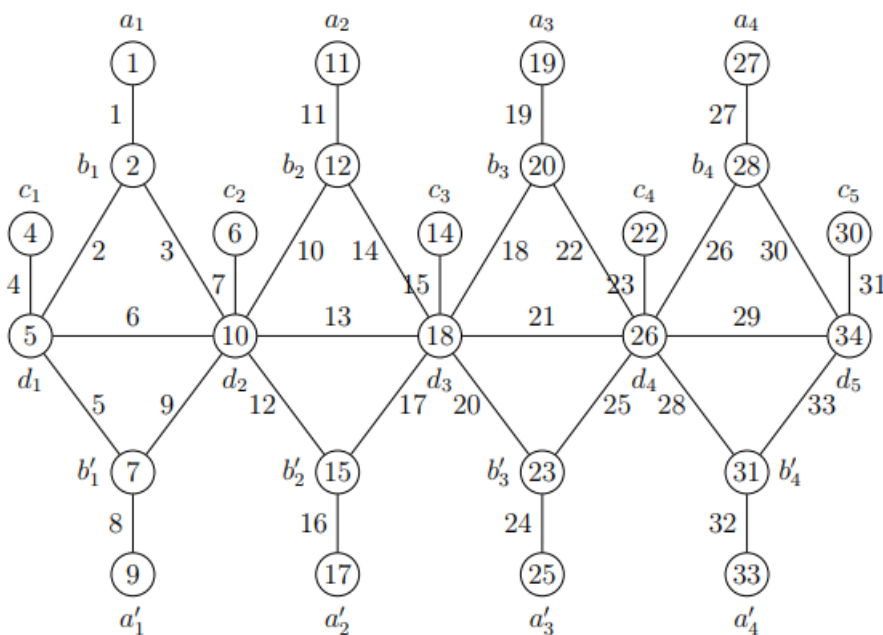

Fig. 3.  $DTS_4 \circ K_1$

**Theorem 3.4.** For every  $n \geq 1$ , there exists a Alternate Double Triangular snake graph  $A(DTS)_n \circ K_1$ , which admits HM labeling.

**Proof.** Consider the  $A(DTS)_n \circ K_1$  graph with Vertex set  $V = \{a_i, b_i, c_i, d_i, a'_i, b'_i; 1 \leq i \leq n\}$  and Edge set  $E = \{(a_i b_i) \cup (d_i b_i) \cup (c_i d_i) \cup (d_i d_{i+1}) \cup (b'_i d_i) \cup (a'_i b'_i); 1 \leq i \leq n\}$  Now let us define a function

$$\rho: v \rightarrow \{1, 2, 3, \dots, q + 1\}$$

Let us label the vertices as follows.

$$\rho(a_1) = 1; \rho(a_{i+1}) = 10i + 3; 1 \leq i \leq n - 1$$

$$\rho(b_i) = 10i - 8; 1 \leq i \leq n$$

$$\rho(d_1) = 5; \rho(d_{2i}) = 10i; i \equiv 0(\text{mod}2) \rho(d_{2i-1}) = 10i + 1; i \equiv 1(\text{mod}2)$$

$$\rho(c_{2i}) = 10i - 4; i \equiv 0(\text{mod}2) \rho(c_{2i-1}) = 10i - 6; i \equiv 1(\text{mod}2)$$

$$\rho(b'_i) = 10i - 3; \rho(a'_i) = 10i - 1; 1 \leq i \leq n$$

The induced edge labeling is as follows

$$\begin{aligned} \rho^*(a_1b_1) &= 1; \rho^*(a_{i+1}b_{i+1}) = 10i + 2; 1 \leq i \leq n - 1 \\ \rho^*(d_1c_1) &= 4; \rho^*(d_{2i}c_{2i}) = 10i - 3; i \equiv 0(\text{mod}2) \rho^*(d_{2i+1}c_{2i+1}) = 10i + 3; i \equiv 1(\text{mod}2) \\ \rho^*(d_1b_1) &= 2; \rho^*(d_{2i+1}b_{i+1}) = 10i + 1; 1 \leq i \leq n \\ \rho^*(d_2b_1) &= 3; \rho^*(d_{2i+2}b_{i+1}) = 10i + 6; 1 \leq i \leq n \\ \rho^*(d_2d_1) &= 3; \rho^*(d_{2i}d_{2i+1}) = 10i; \rho^*(d_{2i+1}d_{2i+2}) = 10i + 5; 1 \leq i \leq n \\ \rho^*(b'_{i+1}d_{2i+1}) &= 10i + 4; \rho^*(b'_i d_{i+1}) = 10i - 1; 1 \leq i \leq n \\ \rho^*(a'_1b'_i) &= 10i - 2; 1 \leq i \leq n \end{aligned}$$

Thus,  $A(DTS)_n \circ K_1$  is a HM labeling.

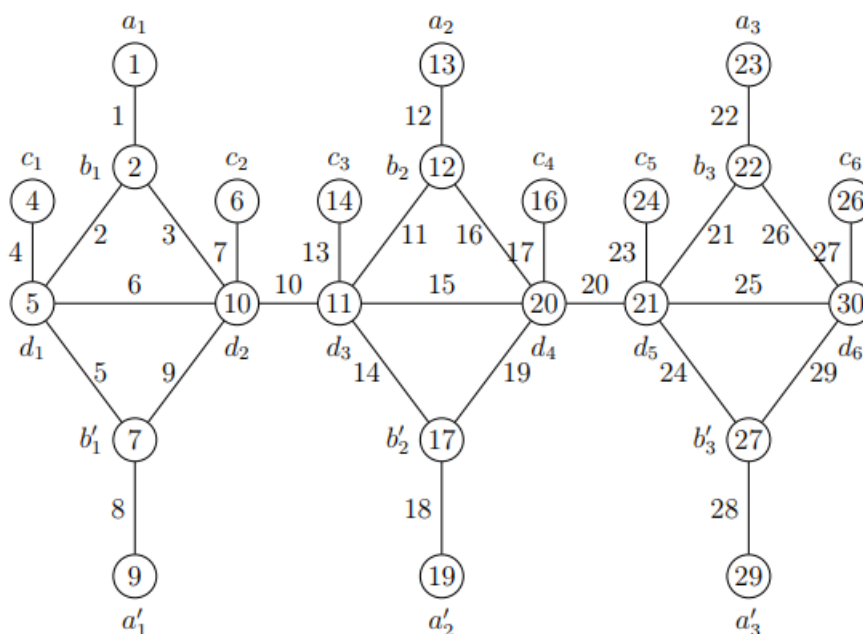

Fig. 4.  $A(DTS)_3 \circ K_1$

**Theorem 3.5.** For every  $n \geq 1$  there exists a Triple Triangular snake graph  $T^3S_n \circ K_1$ , which admits HM labeling.

**Proof.** Consider the  $T^3S_n \circ K_1$  graph with Vertex set  $V = \{a_i, b_i, c_i, d_i, a'_i, b'_i, d'_i; 1 \leq i \leq n\}$  and Edge set  $E = \{(a_i b_i) \cup (d_i b_i) \cup (c_i d_i) \cup (d_i d_{i+1}) \cup (b'_i d_i), \cup (a'_i b'_i) \cup (d'_i d_i); 1 \leq i \leq n\}$

Now let us define a function

$$\rho: v \rightarrow \{1, 2, 3, \dots, q + 1\}$$

Let us label the vertices as follows.

$$\begin{aligned} \rho(a_1) &= 1; \rho(a_{i+1}) = 10i + 4; 1 \leq i \leq n - 1 \\ \rho(b_1) &= 2; \rho(b_{i+1}) = 10i + 5; 1 \leq i \leq n - 1 \\ \rho(d_1) &= 5; \rho(d'_{i+1}) = 10i + 2; 1 \leq i \leq n - 1 \\ \rho(d_1) &= 6; \rho(d_{i+1}) = 10i + 1; 1 \leq i \leq n - 1 \\ \rho(c_i) &= 10i + 3; \rho(b'_i) = 10i - 2; \rho(c'_i) = 10i - 1; 1 \leq i \leq n \end{aligned}$$

The induced edge labeling is as follows

$$\begin{aligned} \rho^*(a_1b_1) &= 1; & \rho^*(a_{i+1}b_{i+1}) &= 10i + 4; & 1 \leq i \leq n - 1 \\ \rho^*(d'_1d_1) &= 6; & \rho^*(d'_{i+1}d_{i+1}) &= 10i + 1; & 1 \leq i \leq n - 1 \\ \rho^*(d'_1b_1) &= 2; & \rho^*(d'_{i+2}b_{i+1}) &= 10i + 3; & 1 \leq i \leq n - 1 \\ \rho^*(d'_2b_1) &= 3; & \rho^*(d'_{2i}b_{i+1}) &= 10i + 8; & 1 \leq i \leq n - 1 \\ \rho^*(d'_1c_1) &= 4; & \rho^*(d'_{2i+1}c_{i+1}) &= 10i + 2; & 1 \leq i \leq n - 1 \\ \rho^*(d'_2c_1) &= 5; & \rho^*(d'_{2i}c_{i+1}) &= 10i + 7; & 1 \leq i \leq n - 1 \\ \rho^*(d'_2d_2) &= 8; & \rho^*(d'_{2i+1}c_{2i+2}) &= 10i + 6; & 1 \leq i \leq n - 1 \\ \rho^*(b'_1d'_1) &= 7; & \rho^*(d'_{i+2}b'_{i+1}) &= 10i + 5; & 1 \leq i \leq n - 1 \\ \rho^*(b'_id'_{2i}) &= 10i; & \rho^*(a'_ib'_i) &= 10i - 1; & 1 \leq i \leq n \end{aligned}$$

Thus,  $T^3S_n \circ K_1$  is a HM labeling.

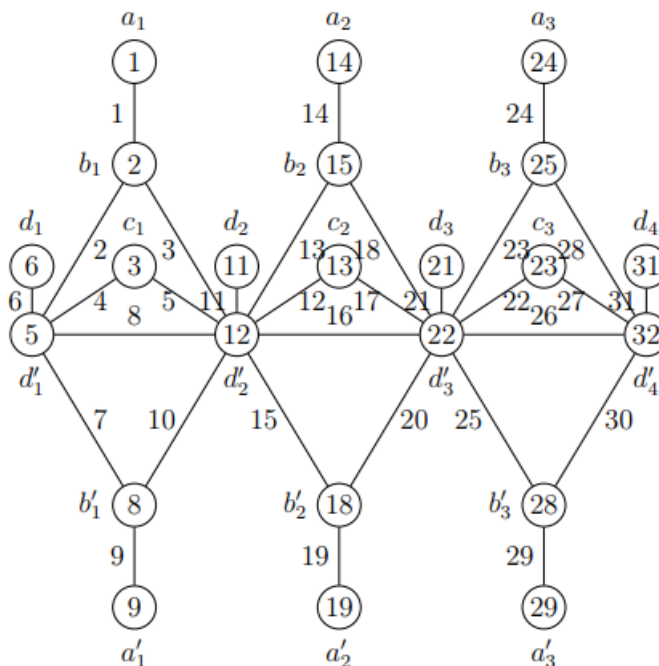

Fig. 5.  $T^3S_3 \circ K_1$

## 4. Application

### Definition 4.1. Plain text

An original intelligible message is called as Plain text.

### Definition 4.2. Cipher text

The Transformed message after coding is called as Cipher text.

In this section, We used HM Labeling of  $TS_n \circ K_1$  Graph to encode a message and created novel encoding and decoding techniques that increase the secrecy of the coded message.

### 4.3. Algorithm for Encoding

- First assign the values of the alphabet ranges over 1-26.
- It is the original position of the alphabet. Then shift the alphabet using the formula  $y = (x + n)(\text{mod}26)$ , where  $x$  denotes the original position of the alphabet and  $n$  denotes the length of the word. In this way, encoding table was created.
- Convert the plaintext message into a sequence of integers using the encoding table.
- Construct the  $TS_n \circ K_1$  graph corresponding to the length '  $n$  ' of the plaintext message  $TS_n \circ K_1$  graph, Let  $b_i, c_i$  be the vertices of a Triangular snake . Let  $a_i, d_i$  be the pendent vertices join  $a_i, b_i$  and  $c_i, d_i$
- $v_i$  denotes the vertices in the graph.  $e_i$  denotes the edges in the graph.  $w_i(e_i)$  denotes the weights of each edges.
- Next, the weights  $w_1, w_2, \dots, w_n$  to each to the edges  $e_1, e_2, \dots, e_n$  in such a way that  $W_1(e_1) < W_2(e_2) \dots W_n(e_n)$ .

#### 4.3.1. Method for calculating weight of edges

- find the weight of each edge  $w_i(e_i)$  by the formulation.  $w_i(e_i) = (\text{Numerical value of vertex } v_i \text{ corresponding to the edge } e_i) - 10i$ , where  $i = 1, 2, 3 \dots n$ .
- The resulting values are the weight of each edge. Now assign the weight of each edge in the  $TS_n \circ K_1$  graph.
- Finally send this graph to the receiver by hiding the values of the vertex which is known as encrypted message along with the public key 10.

### 4.4. Algorithm for Decoding

- Arrange the weights of edge in ascending order of mod values and add the multiples of 10 respectively.



- Decode the cipher text into plain text message from the encoding table to get the original plain text message.
- Plaintext: Bishop

**4.5. Encoding**

- Length of the message = 6,  $y = (x + n)(\text{mod}26)$
- Construct the  $TS_n \circ K_1$  graph by assigning the above sequence of integers to the vertices of the  $TS_n \circ K_1$  graph.

Table 1. Encoding Table

A	B	C	D	E	F	G	H	I	J	K	L	M
7	8	9	10	11	12	13	14	15	16	17	18	19
N	O	P	Q	R	S	T	U	V	W	X	Y	Z
20	21	22	22	23	24	25	26	1	2	3	5	6

Each letter from the table above represented as follows

B	I	S	H	O	P
8	15	25	14	21	22

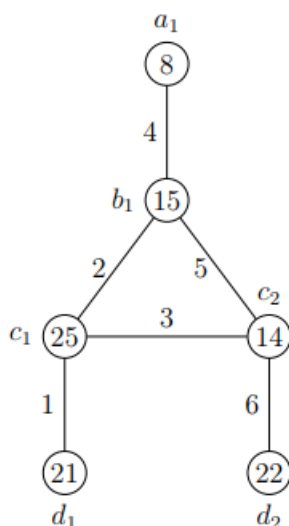

Fig. 6. Encoding

- Applying weights to the  $w_i, i = 1,2,3,4,5,6$  to the corresponding edges of the vertices  $w_1(8) < w_2(15) < w_3(25) < w_4(14) < w_5(21) < w_6(22)$ .
- Weights are obtained by subtracting the multiples of 10 from each adjacent numeric value of the vertices.
- Weight of edge

$$\begin{aligned}
 e_1 &= w_1 = 8 - 10 = -2 \\
 e_2 &= w_2 = 15 - 20 = -5 \\
 e_3 &= w_3 = 25 - 30 = -5 \\
 e_4 &= w_4 = 14 - 40 = -26 \\
 e_5 &= w_5 = 21 - 50 = -29 \\
 e_6 &= w_6 = 22 - 60 = -38
 \end{aligned}$$

- Cipher graph is created by assigning the weight of each edge and hiding the values of the each vertices.

#### 4.6. Encrypted Message

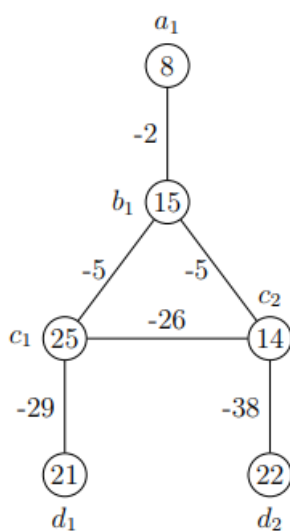

Fig. 7. Encryption

#### 4.7. Decryption

- The receiver receives the encrypted message.
- Arrange the weights of edges in ascending order of mod values  $|-2| < |-5| < |-5| < |-26| < |-29| < |-38|$
- Adding the multiples of 10 to each adjacent value:  $|-2 + 1(10)| < |-5 + 2(10)| < |-5 + 3(10)| < |-26 + 4(10)| < |-29 + 5(10)| < |-38 + 6(10)|$
- Sequence of integers is 8,15,25,14,21,22
- 8,15,25,14,21,22 = B, I, S, H, O, P

Therefore, we deduce from the encoding table that the plain text is BISHOP.

## 5. Conclusion

In this paper, we investigated some families Triangular Snake graphs satisfy the condition of Harmonic mean labeling. We presented secret coding by using a revised GMJ technique with new labeling and numbering of alphabets based on vowels. In the future, we intend to introduce new labeling technique and prove coding, utilising various graphs in conjunction with various methods of alphabet numbering.

It is very interesting and challenging as well as to investigate graph families which admit Harmonic Mean Labeling graph. We have presented new results on the Harmonic mean labeling of certain classes of graphs like  $TS_n \circ K_1$ . Analogous work can be carried out for other families and in the context of different types of graph labeling techniques.

## References

- [1] Gallian, J. A. (2018). A dynamic survey of graph labeling. *Electronic Journal of combinatorics*, 1(DynamicSurveys), DS6.
- [2] Harary, Graph theory, Addison Wesley, Massachusetts, 1969.
- [3] Somasundaram, S., & Ponraj, R. (2003). Mean labelings of graphs. *National academy Science letters*, 26(7-8), 210-213.
- [4] David Raj, C., Jayasekaran, C., & Sandhya, S. S. (2016). Few families of harmonic mean graphs. *Journal of Combinatorial Mathematics and Combinatorial Computing*, 96, 235-243.
- [5] Meena, S., & Sivasakthi, M. (2019). Harmonic Mean Labeling Subdivision Graphs. *International Journal of Research and Analytical Reviews*, 6(1), 2348-1269.
- [6] Somasundaram, S., Sandhya, S. S., & Ponraj, R. Harmonic mean labeling of Graphs, Communicated to *Journal of combinatorial mathematics and combinational computing*.
- [7] Sandhya, S. S., Somasundaram, S., & Ponraj, R. (2012). Some more results on harmonic mean graphs. *Journal of Mathematics Research*, 4(1), 21.
- [8] Sandhya, S. S., Somasundaram, S., & Ponraj, R. (2012). Some results on harmonic mean graphs. *Int. J. Contemp. Math. Sci*, 7, 197-208.
- [9] Sandhya, S. S., Somasundaram, S., & Ponraj, R. (2012). Harmonic mean labeling of some cycle Related graphs, *International Journal of Mathematical Analysis*, 6(37), 1997-2005.
- [10] Somasundaram, S, Ponraj, R and Sandhya, S.S, Harmonic Mean Labeling of Graphs Communicated.